

***Power-edge.ch***

# ***Power-edge***

## ***Race***



User manual

Congratulations on your purchase of a **Power-edge Race** ski edge sharpening machine!



Your **Power-edge Race** will allow you to grind regular or hardened ski and/or snowboard edges like a professional tuner to any angle from 86° to 90°.

With minimal effort, you can grind your skis and/or snowboards with very high levels of precision.

The grinding wheel adjusts automatically to different radii on skis and snowboards, has a long life and gives high repeatability and optimal thermal reduction with no overheating of the edges, while the motor guarantees a powerful drive and a long life.

## Important information

Important notes in this User Manual are marked as follows:

	<b>DANGER</b>	<b>Immediate danger to life and limb.</b> This symbol indicates a potentially hazardous situation which if not avoided can cause death or serious injury.
	<b>WARNING</b>	This indicates a situation where failure to follow the instructions could cause damage to equipment or injury to the operator.
	<b>CAUTION</b>	This indicates a situation where failure to follow the instructions could cause damage to equipment.

**NOTE:** Indicates additional information, directions or exceptions, etc..

 **The Power edge meets current CE-regulations**

# Contents

Important information .....	2
General warnings and cautions .....	4
Operating parts.....	5
Setting up .....	6
Connect the power supply to the socket .....	6
Connect the power supply to the Power-edge.....	6
Using the Power-edge.....	7
Prepare Skis or Snowboard.....	7
Set the grinding angle.....	7
Position the Power-edge .....	8
Power on and begin grinding.....	9
Techniques and tips.....	9
Maintenance operations .....	10
Replacing or reversing the grinding disc .....	12
Using different grinding wheels .....	13
Handling, transporting and storage.....	14
Technical Data .....	14
Troubleshooting.....	14
Warranty.....	15
Warranty exclusions.....	15

# General warnings and cautions



## **DANGER**

Risk of electric shock with improper handling of the power supply or using with a damaged cable. Read this manual before use.



## **WARNINGS**

- Use the Power-edge only if you acknowledge the risks, are fully aware and are personally willing to assume responsibility for these risks.
- The operator is fully responsible for the use of Power-edge. Therefore, the manufacturer disclaims any responsibility for the use of the Power-edge.
- Improper use of the Power-edge can cause damage to ski, snowboard and edges.
- The Power-edge is designed to grind and sharpen the side edges only.
- Use the Power-edge only after fully reading and understanding this operation manual.
- Keep this manual with you and always refer to it regularly before using the Power-edge.
- Never touch the grinding wheel during operation of Power-edge.
- Never operate the Power-edge without the protective cover fitted.
- Make sure that you cannot catch loose objects such as clothing in the grinding wheel.
- Always wear protective goggles and a protective mask when operating the Power-edge, during cleaning or during the dressing of the grinding wheel.
- Only use the Power-edge in dry conditions.
- Check before every use that the grinding wheel is tightened sufficiently.
- Note that the Power-edge is semi-professional equipment, and as such is calculated with a capacity of about 30 minutes grinding time per use. For professional use, with longer operating times, the manufacturer offers no warranty.
- Perform frequent inspections and maintenance of the Power-edge. See 'Maintenance' section.
- After any prolonged use, ensure that any grinding residue under the wheel cover is removed before storage.

# Operating parts

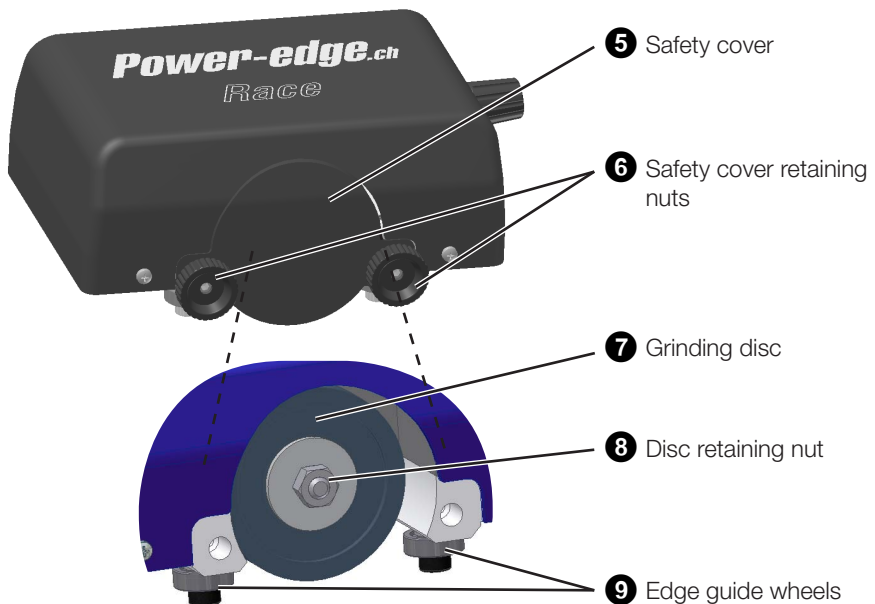
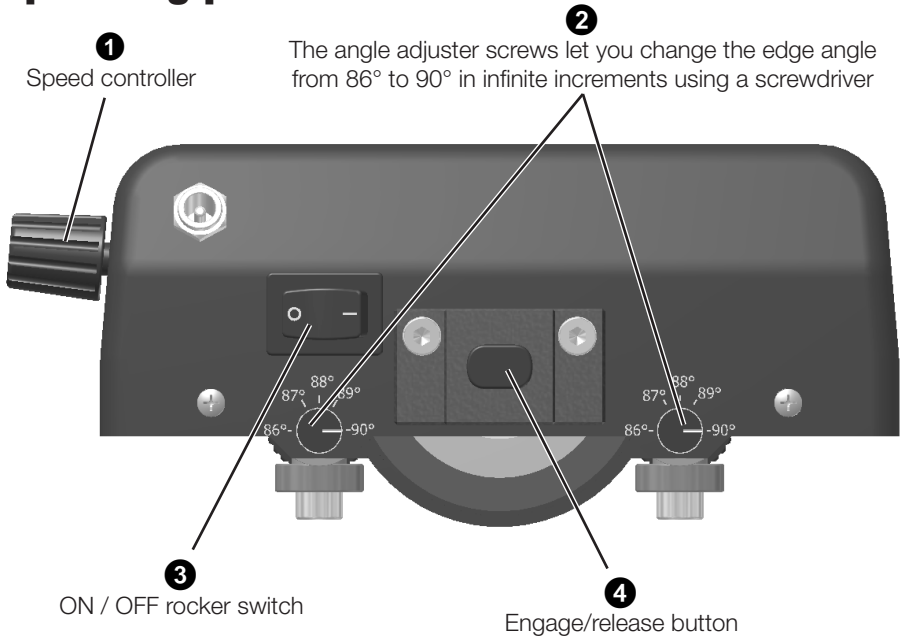

# Setting up

## Connect the power supply to the socket

Insert the adaptor main power supply plug into a 230/110 Volt outlet.

## Connect the power supply to the Power-edge

Insert the adaptor's secondary plug into the corresponding socket on the Power-edge



# Using the Power-edge

## Prepare Skis or Snowboard

Use a brake retainer to lift ski-brakes up and out of the way.

Make sure that the sidewalls are recessed from the metal edge. If necessary, cut the sidewalls away with a sidewall planer or a body file. If the sidewall is not cut back, the grinding wheel may become clogged by sidewall plastic and will not work effectively. Similarly, any wax residue and any other dirt on the edges must also be removed to avoid clogging the wheel.

Secure the ski/board upside-down with the base to the top. Do not clamp the ski/board, just rest it on non-slip supports.

**NOTE:** Grinding is much easier if you use a suitable commercial ski or snowboard vice.

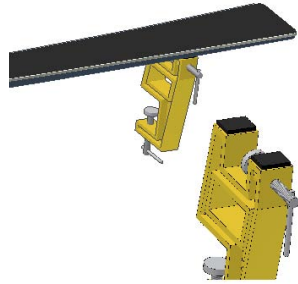

## Set the grinding angle

Use a screwdriver to adjust both angle-adjustment screws to the desired angle (commonly 88° but check the ski/board manufacturer first).

**Make sure both screws are set to the same angle.**

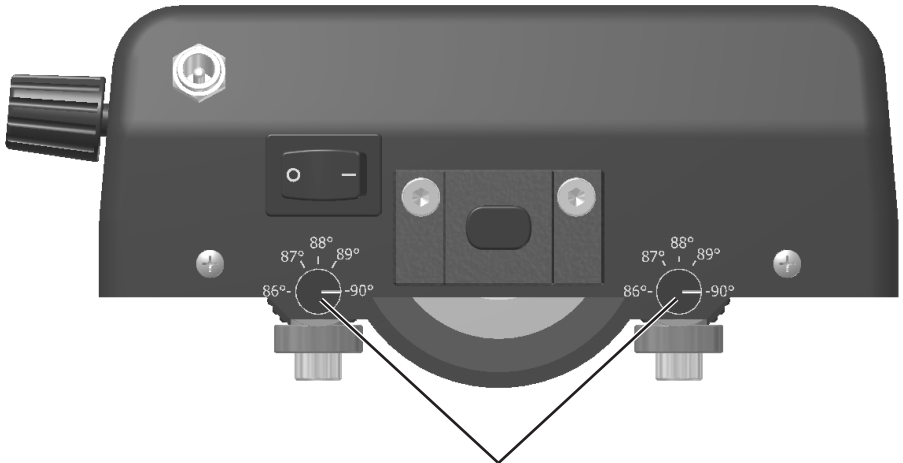

Ensure both angle adjusters (2) are set to the same angle

## Position the Power-edge

With the Power-edge turned off, position it on the upturned ski/board with the guide rollers resting on the base surface of the ski or snowboard. The Edge guide wheels should overhang the edge of the ski/board.

At this point, keep the grinding wheel clear of the edge.

Check that the length of the ski/board is free of any obstructions that would impede the continuous movement of the Power-edge.

Make sure the power cord has a sufficiently large loop to allow free movement.



### CAUTION

Ensure that there are no flammable materials (e.g. wax) in the vicinity to avoid fire risk from sparks.

**Press and hold the wheel engagement/release button to keep the wheel away from the edge.**

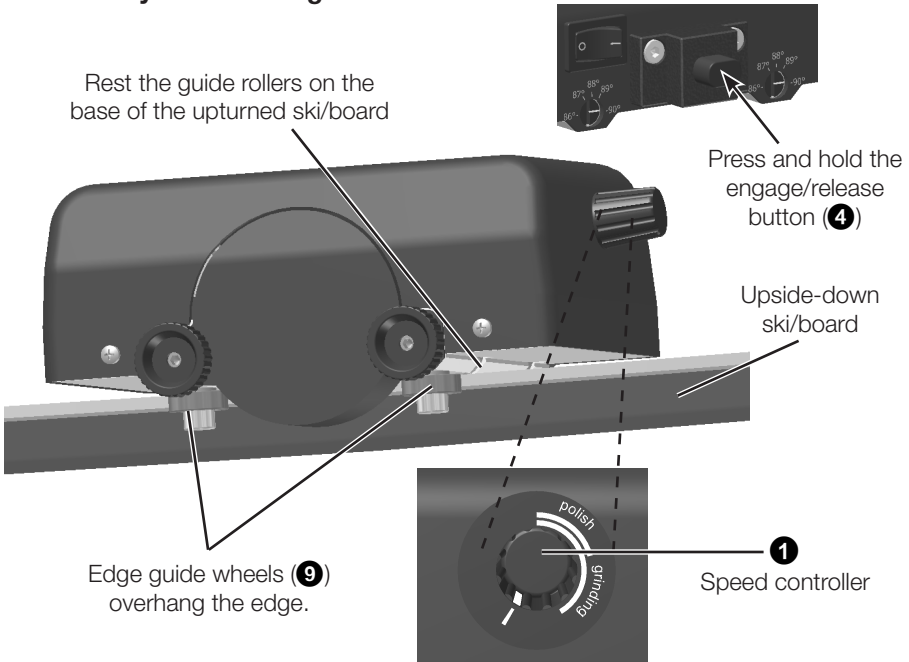

### DANGER

Edge grinding creates hazardous dust! Please wear protective goggles and a mask when operating the Power-edge!

## Power on and begin grinding

Please refer to illustrations on pages 5 and 8.

Ensure the *speed controller* (1) is set to the marked stop, press the *engage/release button* (4), then turn on the power with the *rocker switch* (3). Wait for 5 beeps to sound before turning the *speed controller* to the desired speed. The diamond grinding wheel must only be used with the 'polish' setting, as too high a speed will destroy it.

Adjust the Power-edge so that the *edge guide wheels* (9) press firmly against the ski/board edge. The contact force must be greater than the axial force of the grinding wheel (approximately 10N or 1kg of pressure).

Slowly release the *engage/release button* (4).

When the wheel makes contact with the metal edge, immediately start to run the Power-edge lengthways along the ski/board from one end to the other and back again. Make sure that you use a steady, uniform speed and do not move too quickly (ideal speed is about one metre every 4-5 seconds).

When you have completed one pass back and forth, push the *engage/release button* (4) to release the wheel from the edge and stop grinding.

Check the edge for sharpness.

## Techniques and tips

Repeat the process as necessary to achieve the desired sharpness, checking the edge regularly. 1-3 passes is usually enough.

You can achieve the best results by grinding initially with a coarse disc (120- or 320-grit), followed by polishing with fine polishing wheel (600 grit). For racing applications, the edges can be polished with the diamond polishing disc (1800-grit).

The final polishing of the edge could also be done manually with an appropriate angle guide and diamond file.

For edges that are kept in good condition, the 320-grit wheel is the best compromise between speed and quality.

Note that angle changes (e.g. altering a 90° edge to 88°) will require more passes because more edge material needs to be removed. Also ensure that the sidewall is cut back enough to allow for this.

It is recommended to always use the same angle on the same pair of skis/snowboard to avoid unnecessary edge removal.

Allow the unit to cool periodically when sharpening for longer stints to avoid overheating the unit.



## **WARNING**

Edges sharpened with the Power-edge are extremely sharp. Please take precautions to avoid hurting yourself and others.

# Maintenance operations

## **User inspection**

Check the Power-edge before each use. If you suspect a malfunction of the Power-edge, return the product to the manufacturer for review and/or repair. Repairs may only be performed by the manufacturer. Damaged components which could cause safety defects on the Power-edge must be replaced only with original parts.

## **Cleaning the Grinding disc**

With the Power-edge switched on, clean the grinding disc by briefly touching the face of the wheel with a wire brush (wear protective goggles and mask).

## **Wheel dressing**

If the face of the grinding wheel is no longer flat or becomes damaged, you can re-flatten the grinding area using a dressing stone (e.g. old grinding stone) or dressing stones/diamonds (wear protective goggles and mask.)

## **General cleaning**

Clean the exterior surfaces only with a cloth dampened with soap and water. Do not soak the unit.

Never use harsh solvent cleaners, abrasives or polishing agents. Using strong cleaning agents such as alcohol can result in dulling or cracking of the finish.

Do not use compressed air to clean the unit.



## **CAUTIONS**

- Never use a damaged or faulty Power-edge.
- Use only original grinding discs.
- Never use damaged grinding discs.
- Do not open the Power-edge. There are no user-serviceable parts inside the unit.
- Never use a different power supply from the one supplied.

## Cleaning and lubricating the shaft

The shaft must be cleaned and lubricated periodically:  
Ensure the unit is disconnected from the power supply.  
Remove the grinding disc protective cover.  
Pull the grinding disc away from the unit using light pressure.  
Holding the wheel, clean the shaft with a brush.  
After cleaning the shaft must be oiled or greased lightly with a brush.

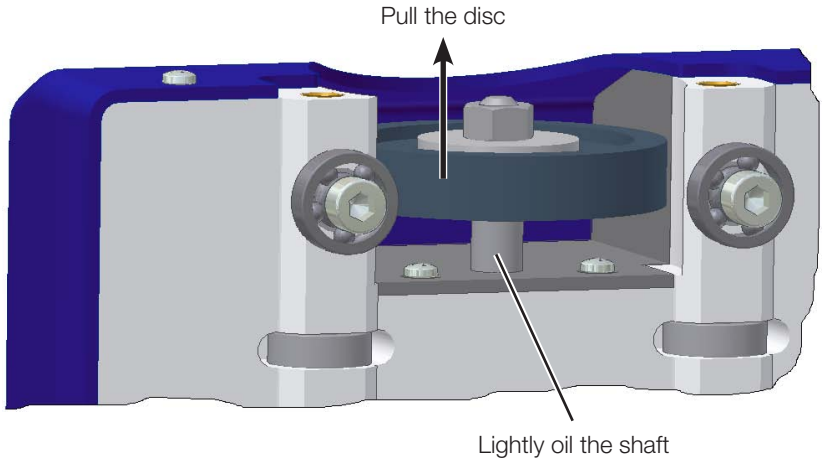

### **Interval**

#### **Before each use**

### **Operation**

- Check for signs of abrasion and damage to the grinding disc.
- Check all cables for damage.
- Make sure you operate the Power-edge in a safe environment

#### **After each use**

- Clean the grinding dust from the unit using a soft, dry cloth or brush.
- Allow the unit to cool down after prolonged use, before replacing it in the case.
- After prolonged use, check for possible build-up of hot abrasive particles under the cover and remove if necessary.

# Replacing or reversing the grinding disc

The grinding disc can be flipped over or replaced when it is worn out.

Loosen the knurled *retaining nuts* (6) of the *safety cover* (5) and remove the cover.

Hold the *grinding disc* (7) still with your thumb and forefinger, then loosen the *retaining nut* (8) with a 10 mm spanner.

Pull the *grinding disc* (7) off the shaft and flip it over or replace it.

When re-mounting the grinding wheel, simply reverse the removal procedure. Please do not over-tighten the retaining nut – the direction of rotation while operating stops the nut from loosening off.

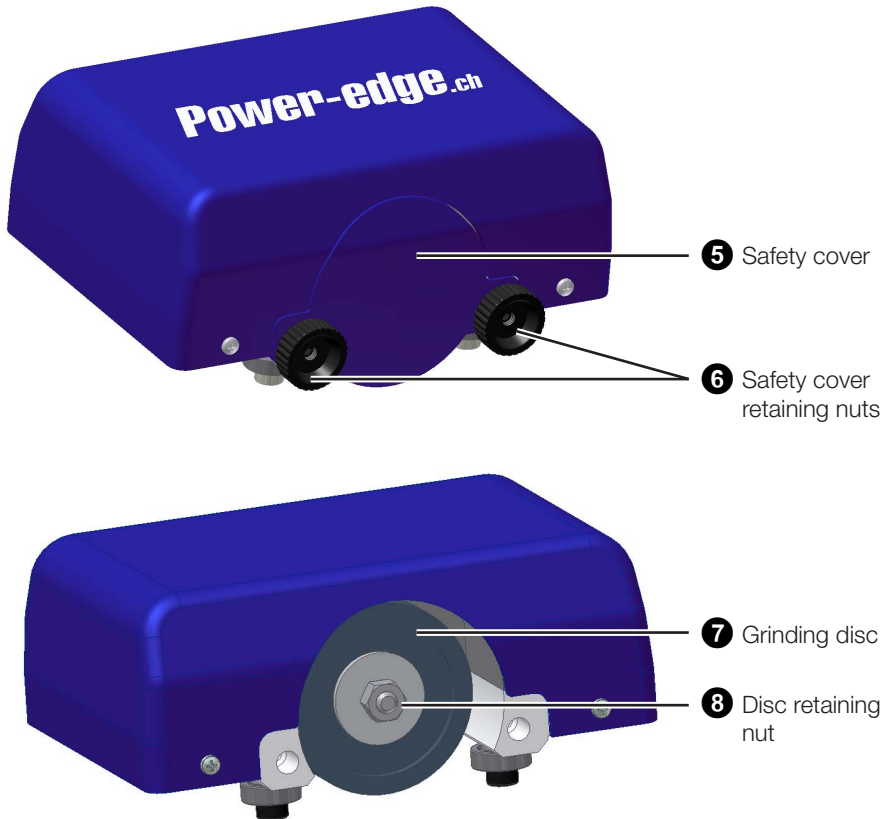

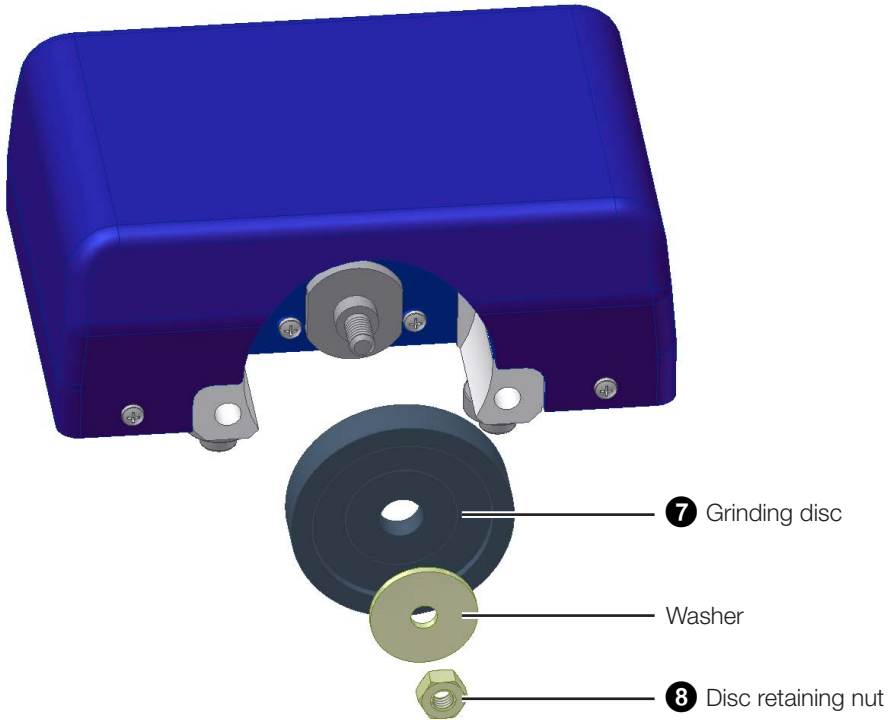

## Using different grinding wheels

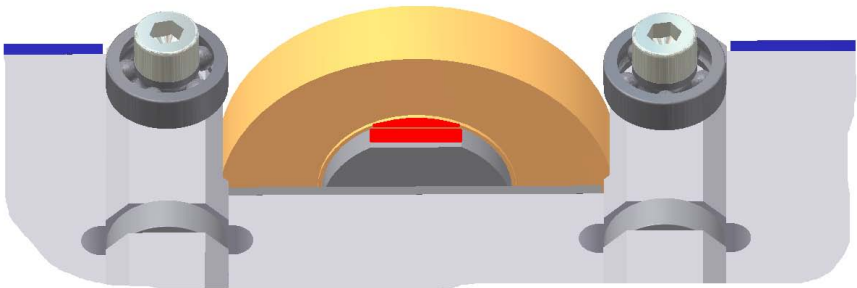

Using different grit grinding wheels will optimise the efficiency of the grinding operation (e.g. a coarse grit will cut more quickly and aggressively than a fine one). Different grits are colour-coded on the flange of the disc and can be identified through the cut-out on the drive-wheel.

# Handling, transporting and storage

- Protect the Power-edge from impact and intensive sun or heat exposure.
- Protect the Power-edge from damp.
- Do not drop the Power-edge. A hard crash can damage the electronic components and the case.
- Do not put heavy articles on the Power-edge.

## Technical Data

<b>Dimensions:</b>	144mm L x 102mm W x 70mm H
<b>Power supply:</b>	100 – 240 VAC / 50-60Hz
<b>Power supply output:</b>	15VDC / 8000 mA
<b>Revolution speed:</b>	Approximately 10500 rpm
<b>Operating temperature:</b>	-10°C to 50°C (14°F to 122°F)
<b>Storage temperature:</b>	-20°C to 50°C (-4°F to 122°F)

## Troubleshooting

Problem	Solution
Edge grinding is not very effective.	The grinding disc pores are blocked. Clean pores with wire brush or dressing stone. Ensure adequate sidewall removal before grinding.  Use a coarser grinding wheel.
The grinding disc strikes during grinding	Dress the grinding disc flat again with a dressing stone or dressing diamond.

# Warranty

The manufacturer assumes liability for this product and assures faultless condition for the period of one year after the purchase date of the product. This warranty is for free repair of the Power-edge within this period and is only valid when a faulty Power edge is returned together with the original proof of purchase.

This guarantee applies only to machines and parts sold by the manufacturer or appointed dealers.

## Warranty exclusions

1. Regular inspection, maintenance and repair or replacement of normal wear and tear parts.
2. Transportation/shipping costs that are directly or indirectly in connection with this guarantee.
3. Any damage to the power-edge caused by:
  - Abuse or misuse of the Power-edge, especially in a country other than described in this manual use.
  - Non-compliance with the usage and/or maintenance instructions.
  - Professional use (see page 4).
  - Any repairs not carried out by the manufacturer.
  - Accidents or environmental damage beyond the control of the manufacturer, e.g. damage from flooding, fire, noise, interference and acidic solutions.

This guarantee does not restrict the national law for the customer. Unless the national law says otherwise, the customer has the right to this guarantee, but the manufacturer takes no guarantee or responsibility for direct or indirect damage or loss connected to the use of the Power-edge.

## **Address & contact information**

Manufacturing Power Edge  
Tannliweg 415  
5112 Thalheim  
Switzerland

Email: [technik@power-edge.ch](mailto:technik@power-edge.ch)

Web [www.power-edge.ch](http://www.power-edge.ch)